

## 2 Wire 4-20mA Sensor and 4 Wire Transmitter Application Note

### 2 Wire 4-20mA Sensors

2 Wire Loop Power sensors from CTC require only 2 connections, a +18 to 30 Volt Power lead and a DC common (negative) lead. The sensor regulates the loop so that the current is proportional to the vibration parameter being measured.

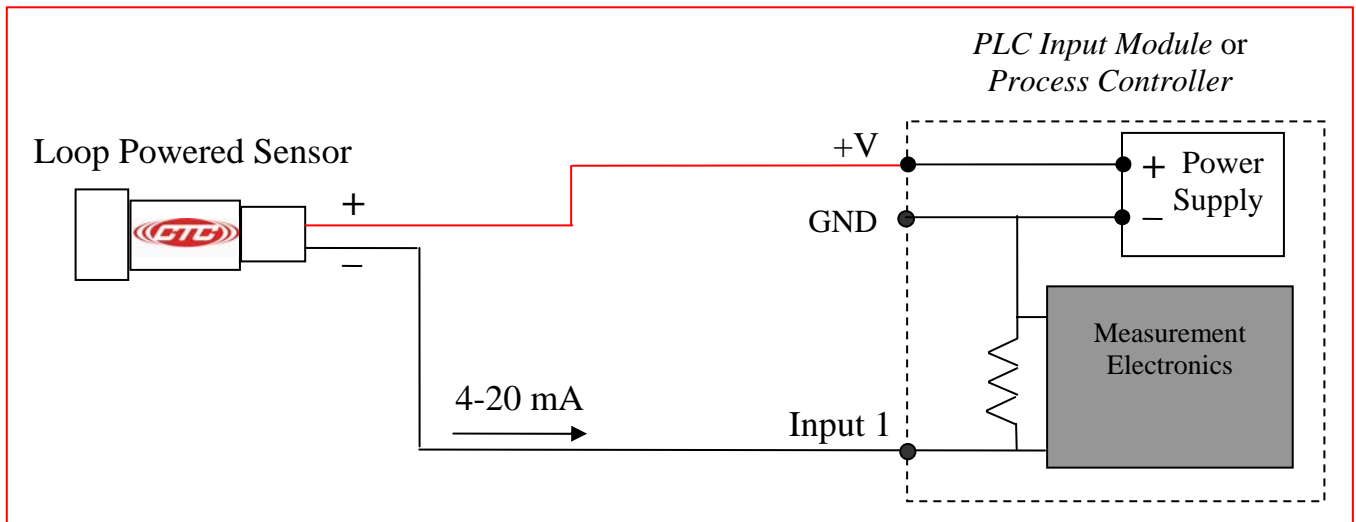

Figure 1

The sensors can be wired directly into analog input modules on PLC's or Process Controllers that accept 4 – 20 mA signals. The sensor must be connected to a power source at the positive lead and the common (negative) lead will be connected to the Controller's Analog Input. The power supply is used to complete the loop through the Controller's Ground. See figure 1.

Figure 2 shows an example of a Loop Powered Sensor's Output vs. Time.

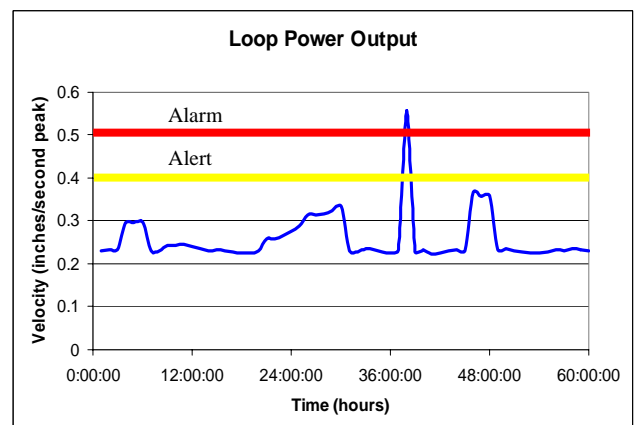

Figure 2



### 4 Wire 4-20 mA Transmitters

CTC's Vibration Transmitters constitute a more versatile approach to continuous monitoring than the standard Loop powered sensors. The transmitters are capable of wider frequency and amplitude ranges and can provide a dynamic vibration signal in addition to the overall 4-20 mA output. The dynamic vibration signal is available through a buffered output. Figure 3 shows an example of the dual outputs of CTC's Vibration Transmitter.

The 4 wires needed to monitor overall vibration level using a transmitter are the Positive and Negative Power Supply leads that will provide power to the electronics, and the Positive and Negative Output SIGNAL leads. These 2 pairs of leads are separate and distinct from one another. Figure 4 shows typical wiring into a PLC or Process controller with analog input module.

A 2 conductor cable with a Plug (F) type BNC Connector can be used to monitor the dynamic vibration signal coming out of the BNC Jack on the Transmitter.

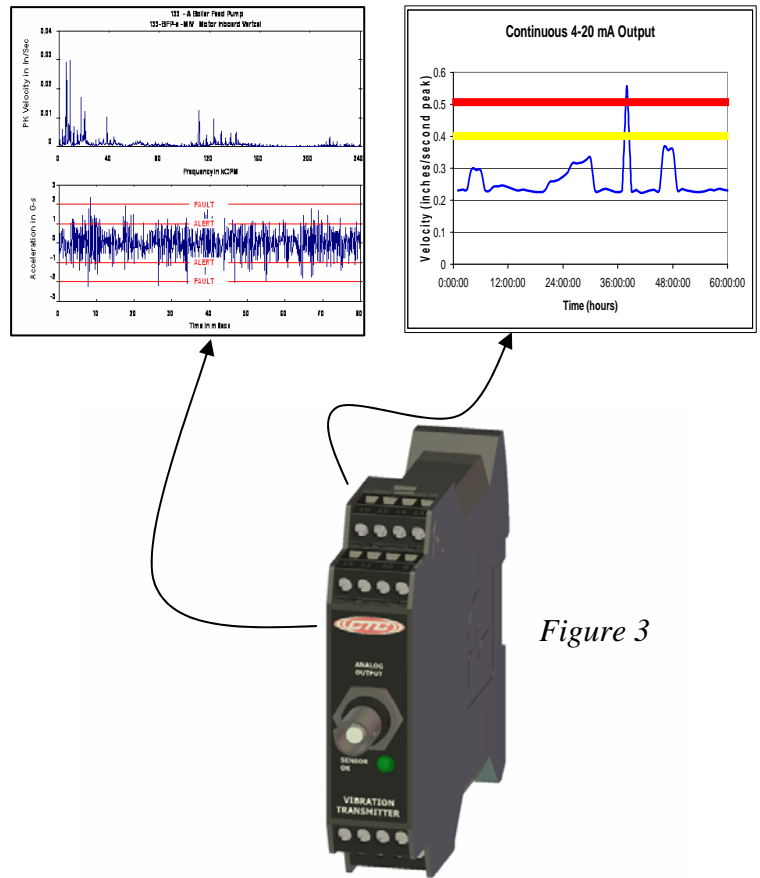
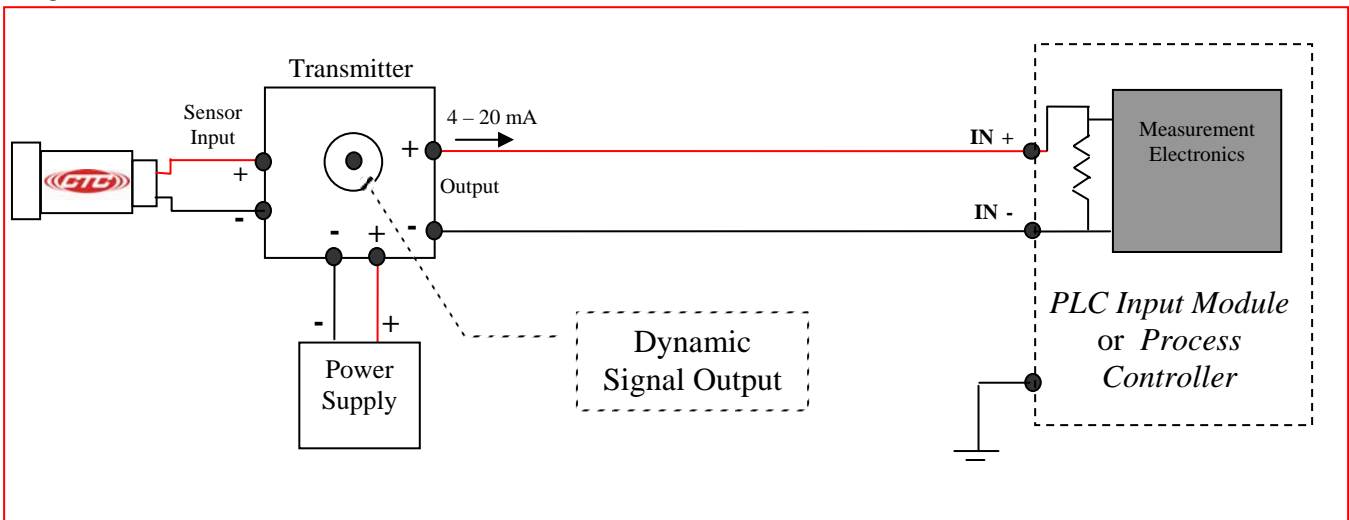

Figure 3

Figure 4



VIBRATION ANALYSIS HARDWARE